

MAX FLEX ALLOY

Quick Fit Vehicle Brake Line Schematic*



2325 Husky Way • Pacific, MO 63069
 Phone: 330.745.3300 • 1.800.390.3996
 Fax: 330.745.3488 • www.surrauto.com

WARNING: Cancer and Reproductive Harm—www.P65Warnings.ca.gov

VEHICLE CONFIGURATION:	
Proportioning Valve	NO
Pre-Charge Pump	NO

- A. Rear Axle Junction to Left Rear Wheel Hose
- B. Rear Axle Junction to Right Rear Wheel Hose
- C. Left Front Wheel Brake Pressure Modulator Valve (ABS Module) Port to Left Front Wheel Hose
- D. Right Front Wheel Brake Pressure Modulator Valve (ABS Module) Port to Right Front Wheel Hose
- E. Rear Brake Pressure Modulator Valve (ABS Module) Port to Rear Axle Junction
- F. Master Cylinder to Brake Pressure Modulator Valve (ABS Module)
- G. Master Cylinder to Brake Pressure Modulator Valve (ABS Module)

KEY	
MC	Master Cylinder
BPMV	Brake Pressure Modulator Valve
RAJ	Rear Axle Junction

* Visual aid to show basic relationships between brake lines and major components only. Refer to vehicle manufacturer repair data for proper routings.

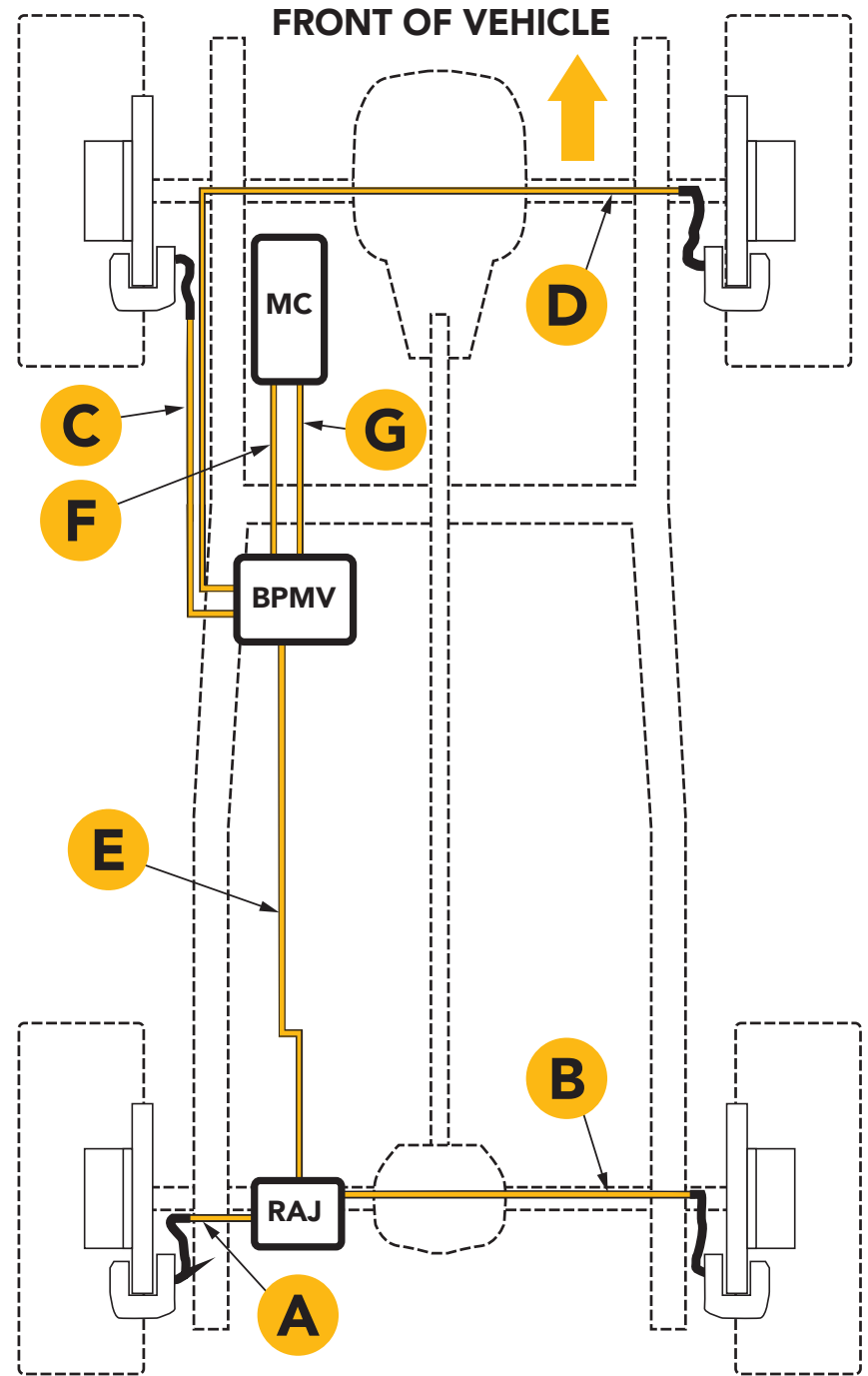
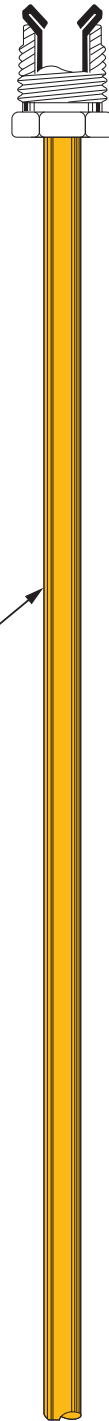

MAX FLEX ALLOY

Quick Fit Vehicle Brake Line Schematic*

VEHICLE CONFIGURATION:

Proportioning Valve	YES
Pre-Charge Pump	NO



2325 Husky Way • Pacific, MO 63069
 Phone: 330.745.3300 • 1.800.390.3996
 Fax: 330.745.3488 • www.surrauto.com

WARNING: Cancer and Reproductive Harm—www.P65Warnings.ca.gov

- A. Rear Axle Junction to Left Rear Wheel Hose
- B. Rear Axle Junction to Right Rear Wheel Hose
- C. Left Front Wheel Brake Pressure Modulator Valve (ABS Module) Port to Left Front Wheel Hose
- D. Right Front Wheel Brake Pressure Modulator Valve (ABS Module) Port to Right Front Wheel Hose
- E. Rear Brake Pressure Modulator Valve (ABS Module) Port to Rear Axle Junction
- F. Master Cylinder to Proportioning Valve
- G. Master Cylinder to Proportioning Valve
- H. Proportioning Valve to Brake Pressure Modulator Valve (ABS Module)
- I. Proportioning Valve to Brake Pressure Modulator Valve (ABS Module)

MAX FLEX
BRAKE LINE

KEY	
MC	Master Cylinder
PV	Proportioning Valve
BPMV	Brake Pressure Modulator Valve
RAJ	Rear Axle Junction

* Visual aid to show basic relationships between brake lines and major components only. Refer to vehicle manufacturer repair data for proper routings.

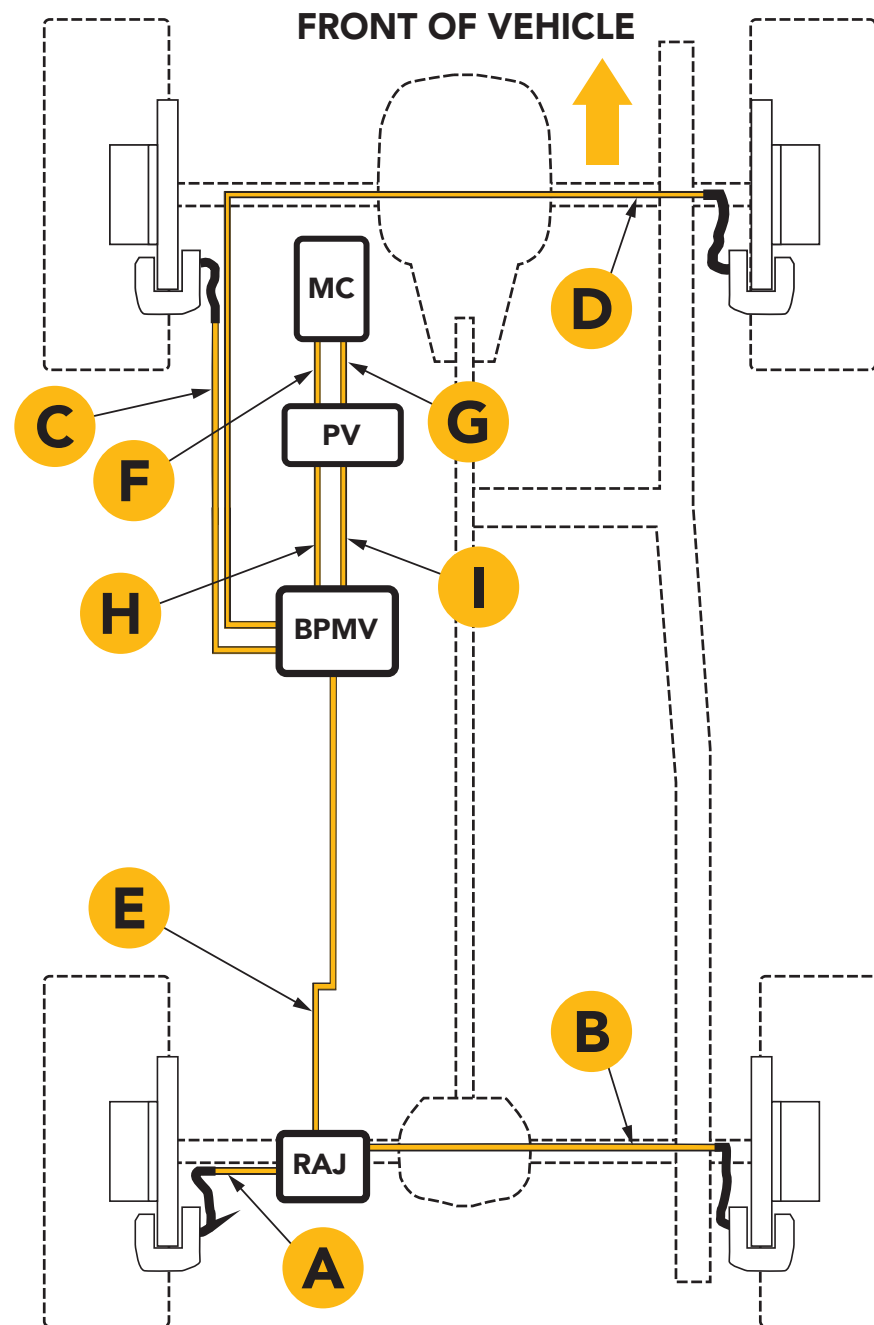
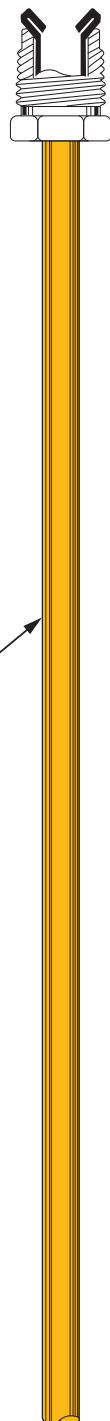

MAX FLEX ALLOY

Quick Fit Vehicle Brake Line Schematic*

VEHICLE CONFIGURATION:

Proportioning Valve	YES
Pre-Charge Pump	YES



2325 Husky Way • Pacific, MO 63069
 Phone: 330.745.3300 • 1.800.390.3996
 Fax: 330.745.3488 • www.surrauto.com

WARNING: Cancer and Reproductive Harm—www.P65Warnings.ca.gov

**MAX FLEX
 BRAKE LINE**

- A. Rear Axle Junction to Left Rear Wheel Hose
- B. Rear Axle Junction to Right Rear Wheel Hose
- C. Left Front Wheel Brake Pressure Modulator Valve (ABS Module) Port to Left Front Wheel Hose
- D. Right Front Wheel Brake Pressure Modulator Valve (ABS Module) Port to Right Front Wheel Hose
- E. Left Rear Brake Pressure Modulator Valve (ABS Module) Port to Rear Axle Junction
- F. Right Rear Brake Pressure Modulator Valve (ABS Module) Port to Rear Axle Junction
- G. Master Cylinder to Proportioning Valve
- H. Master Cylinder to Proportioning Valve
- I. Proportioning Valve to Brake Pressure Modulator Valve (ABS Module)
- J. Proportioning Valve to Brake Pressure Modulator Valve (ABS Module)
- K. Pre-Charge Pump to Proportioning Valve

KEY

MC	Master Cylinder
PV	Proportioning Valve
PP	Pre-Charge Pump
BPMV	Brake Pressure Modulator Valve
RAJ	Rear Axle Junction

* Visual aid to show basic relationships between brake lines and major components only. Refer to vehicle manufacturer repair data for proper routings.

